

Rev	Ind	Revision	Appd	Date

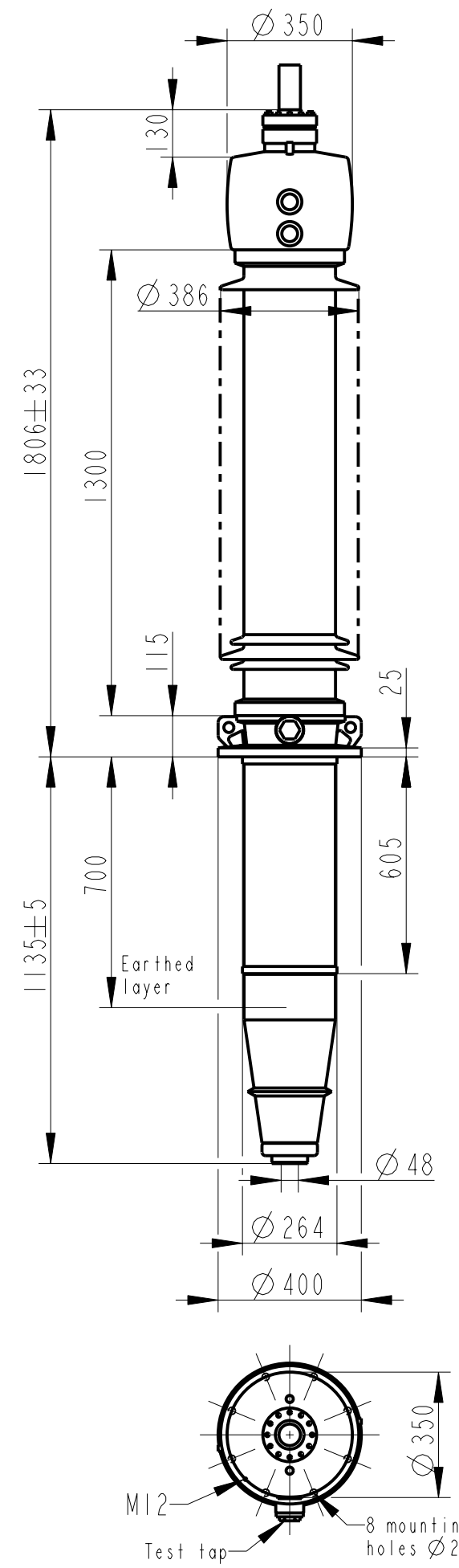

Bushing Data:

Rated Voltage	245	kV
Phase to-earth Voltage	155	kV
Dry Lightning Impulse 1,2/50µs	650	kV
Wet Switching Impulse	500	kV
Wet Power frequency AC	315	kV
Routine test Imin dry 50Hz	325	kV
Rated Current	3150	A
Creepage Distance	4045	mm
Mass	340	kg

Ordering Data:

BUSHING LF121054 -A / -AA COLOUR AIR INSULATOR BROWN / LIGHT GREY

OUTER TERMINAL	H2 (mm)	D2 (mm)
LF170 073-A Al	125	60
LF170 073-B Cu	125	60
LF170 073-G Cu/Ag	125	60
OTHER TYPES ON REQUEST		

END-SHIELD
 LF170 046-U EPOXY INSULATED
 LF170 046-UP INSULATED WITH 3 mm PRESSBOARD

DRAW ROD SYSTEM
 LF170 059 LOWER DRAW ROD WITH NI=4 OR NI=6
 LF170 057 UPPER DRAW ROD

INNER TERMINAL	D3 (mm)	D9 (mm)	Cond.area (mm ²)	Current (A) IEC	IEEE
LF170 056-E 0 *)	45	-	-	-	-
LF170 056-D	40	45	600	1600	1360

*) WITH PILOT HOLE D=5

ABB Components Luleå, Sweden

Urty	Nb	50-60 Hz
U	kV	AC
M	kg	mm
C1	pF	Tanδ
C2	pF	Tanδ

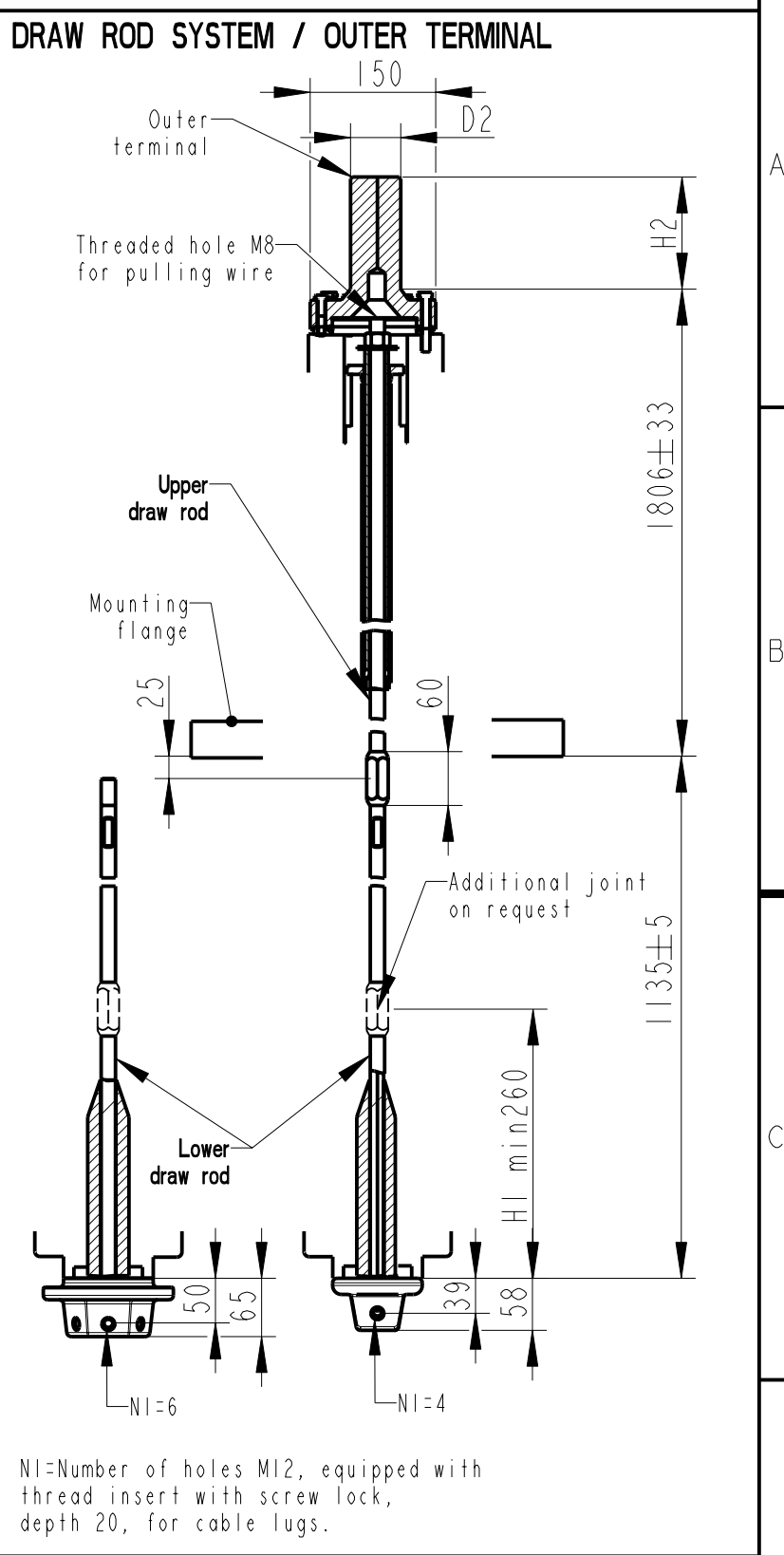
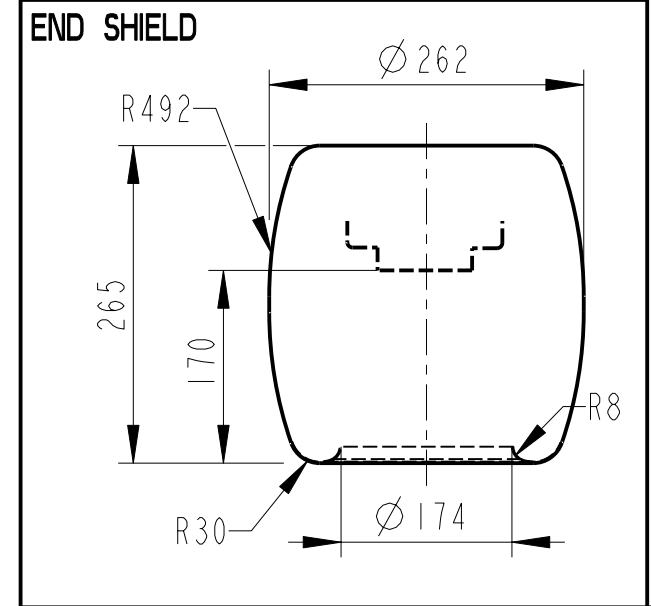
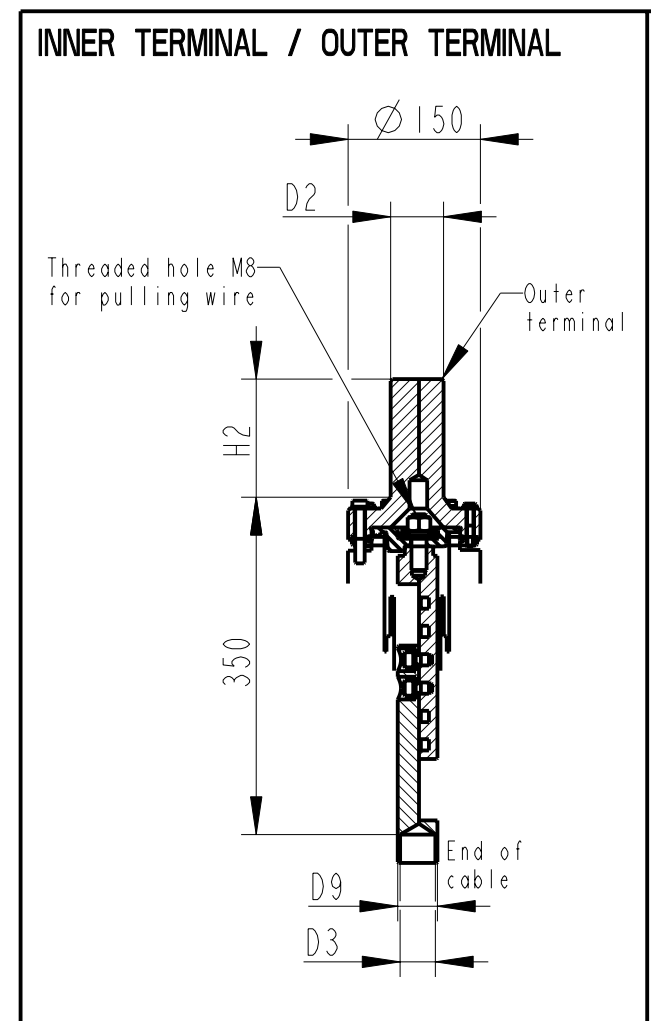

NI=Number of holes M12, equipped with thread insert with screw lock, depth 20, for cable lugs.

Based on	Reg. No.	Title	
Prepared Lövnord	Responsible department COM/BK 0022	GOE-650-500-3150-0.6	
Approved Johansson	Take over department		Language 82
Design engineering review Gutman	Database		Page 1(1)
ABB Components		Document No.	2751369-14

We reserve all rights in this document and in the information contained therein. Reproduction, use or disclosure to third parties without express authority is strictly forbidden. ©ABB